



Local Control and Accountability Plan

District Overview



5

SCHOOLS

High School:	0	E/H Combo:	0
Middle:	1	Adult:	0
Elementary:	4	Ungraded:	0
Preschool:	0	Charter:	0



3,916

STUDENTS

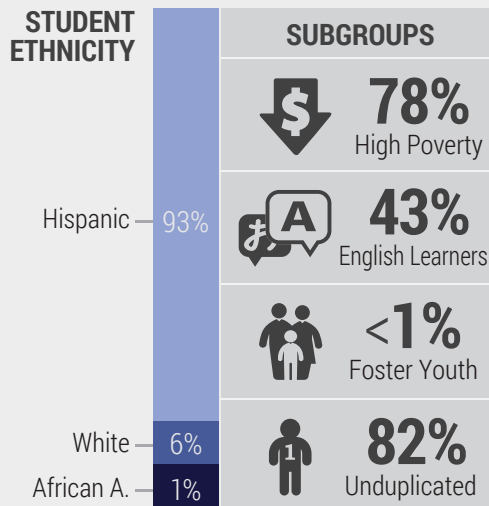

432

EMPLOYEES

STAFF

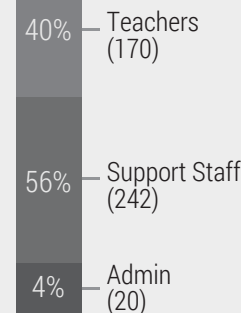

ANNUAL REVENUE



\$34,516,650

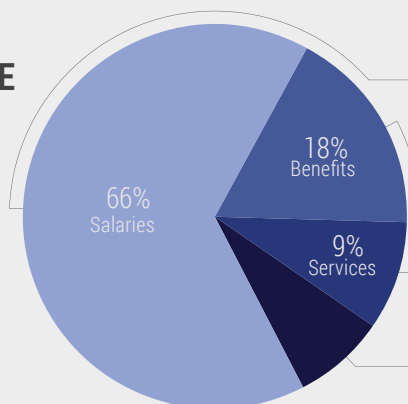

Employee Salaries: \$21,958,079 (66%)

Employee Benefits: \$5,911,474 (18%)

Services / Operations: \$3,024,263 (9%)

Books / Supplies: \$2,568,620 (8%)

Total General Fund Expenditures: \$33,462,436 (100%)

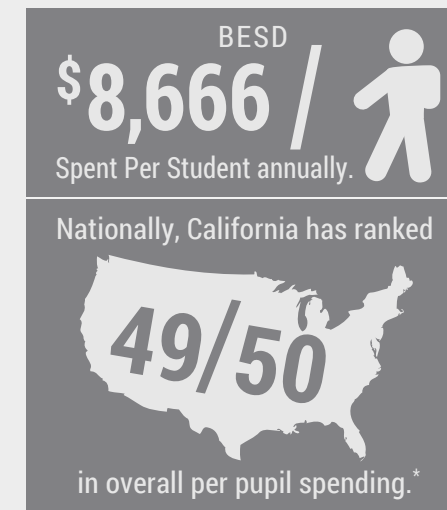
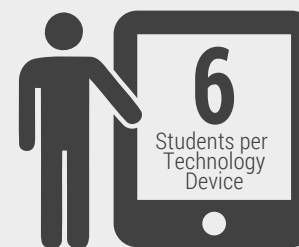
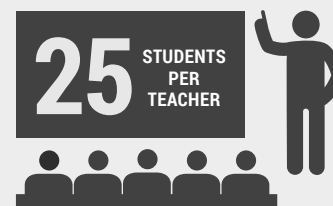

Brawley Elementary School District, 261 D St., Brawley, CA 92227-1912; Phone: (760) 344-2330; Website: www.besd.org; CDS# 1363073.

About This Data: The figures above represent the most recently reported public data available from the California Department of Education, ranging from 2012 to 2014. Some values may not match exactly due to rounding, reporting delays, or anomalies. *State rankings are based on 2011 data in the most recent 2014 Education Week Quality Counts Report Card.

1. Stakeholder Engagement

1,050
SURVEYS
Conducted

6
WORKSHOPS
Held

120
COMMENTS
Received

40+
STAKEHOLDERS
Engaged

4
REVIEWS
Performed

5
BOARD MEETINGS
Convened

11+
GROUPS
Involved

Groups include:
Parents, Students, Teachers, Staff, Administrators, Community, School Site Council, ELAC, GATE Parents, Migrant Parents, DAC, Parent Teacher Organization.



Checklist of Items Shared:

- District Profile Data
- State Education Priorities
- LCAP & LCFF Overview
- School Site Plans
- CELDT data
- Survey data
- CST data
- Healthy Kids survey data
- Discipline data
- Attendance data

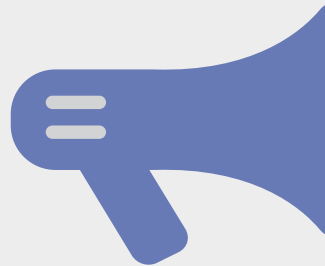

BESD has informed, consulted, and involved school stakeholders in the process of creating the LCAP as summarized above. Communications to stakeholders includes:



District website, automated phone calls, newspaper, radio, television, & events.

State & Local Priorities



THE 8 STATE EDUCATION PRIORITIES

1. Basic Services
2. Academic Standards
3. Parent Involvement
4. Student Achievement
5. Student Engagement
6. School Climate
7. Course Access
8. Other Outcomes

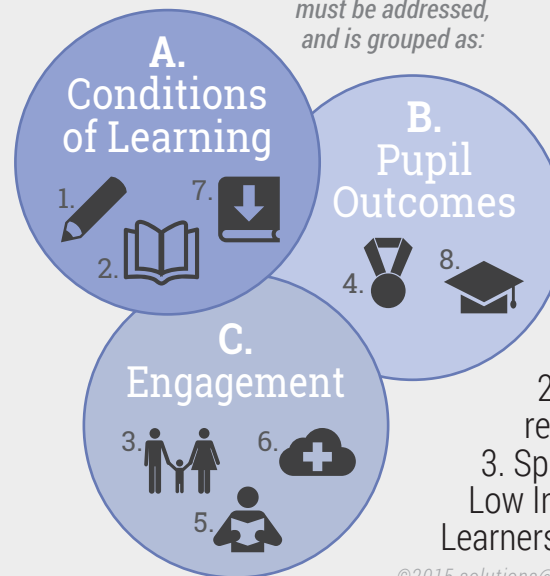

Each State Priority must be addressed, and is grouped as:



Stakeholder input is aligned with California's Education Priorities...

& TOP LOCAL PRIORITIES

1. Equal access to a rigorous curriculum.
2. Career and college readiness.
3. Specialized services for Low Income, English Learners, & Foster Youth.



... and results in Annual Goals...

STATE PRIORITIES SERVED

-  1. Basic Services
-  2. Academic Standards
-  3. Parent Involvement
-  4. Student Achievement
-  5. Student Engagement
-  6. School Climate
-  7. Course Access
-  8. Other Outcomes



GOAL #1



CONTENT AREA PROFICIENCY & ACHIEVEMENT



NEED - 1.0

Based on findings from stakeholders and data, BESD will close the achievement gap for all under performing student groups and assure that all students have equitable access to rigorous, well-rounded, standards-aligned curricula that assures readiness for a full-range of post-graduation options.

GOAL - 1.1

Students will reach high standards attaining proficiency or better in all content areas.

METRICS & OUTCOMES - 1.2

INCREASED STUDENT PROFICIENCY IN ALL CONTENT AREAS ON CCSS-ALIGNED BENCHMARKS

SUBGROUPS SERVED

-  All Students
-  English Learners
-  High Poverty
-  Foster Youth

SCHOOLS

-  
 -  
- All - 100%

STATE PRIORITIES SERVED

-  1. Basic Services
-  2. Academic Standards
-  3. Parent Involvement
-  4. Student Achievement
-  5. Student Engagement
-  6. School Climate
-  7. Course Access
-  8. Other Outcomes



GOAL #2



ALL LEP STUDENTS ENGLISH PROFICIENT

NEED - 2.0

Based on our Annual Measurable Achievement Objective (AMAO) data, (AMAO #1 = 67.2%, AMAO #2 = 29.9 less than 5 yrs and 55.2% 5 yrs or more), many English Learners have not met reclassification criteria by their anticipated reclassification date.

GOAL - 2.1

All Limited English Proficient (LEP) students will become proficient in English as measured by the California English Language Development Test (CELDT).

METRICS & OUTCOMES - 2.2



LEP STUDENT AMAO 1 & 2 CELDT SCORE INCREASE









SUBGROUPS SERVED

-  All Students
-  English Learners
-  High Poverty
-  Foster Youth

SCHOOLS

-  
 -  
- All - 100%

STATE PRIORITIES SERVED

-  1. Basic Services
-  2. Academic Standards
-  3. Parent Involvement
-  4. Student Achievement
-  5. Student Engagement
-  6. School Climate
-  7. Course Access
-  8. Other Outcomes

NEED - 3.0

Based on findings from stakeholders and data, BESD will commit to all students receiving instruction by highly-qualified and effective teachers. Teachers will be supported by receiving ongoing opportunities for professional growth and development.

GOAL - 3.1

All students will be taught by highly qualified teachers. Teachers will receive professional development on Common Core Standards implementation as well as other district adopted programs and initiatives.

METRICS & OUTCOMES - 3.2

 **+1%**



INCREASE PERCENTAGE OF FULLY CREDENTIALLED TEACHERS

 **-1%**



DECREASE RATE OF TEACHER MISASSIGNMENTS

 **+2%**

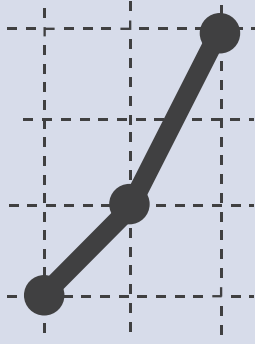

INCREASE SCORES EACH YEAR ON CCSS-ALIGNED BENCHMARKS



HIGHLY QUALIFIED TEACHERS

SUBGROUPS SERVED

-  All Students
-  English Language Learners
-  High Poverty
-  Foster Youth

SCHOOLS

- 
- All - 100%

STATE PRIORITIES SERVED

-  1. Basic Services
-  2. Academic Standards
-  3. Parent Involvement
-  4. Student Achievement
-  5. Student Engagement
-  6. School Climate
-  7. Course Access
-  8. Other Outcomes



GOAL #4

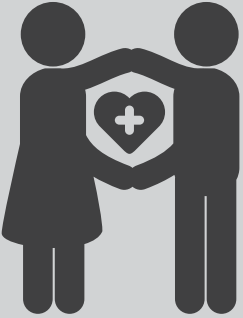

SAFE & ENGAGING LEARNING ENVIRONMENT

NEED - 4.0

Based on findings from stakeholders and data, BESD will develop a safe and supportive school culture, climate, and learning environment that supports physical, mental and emotional health. (94.88% attendance rate, 2984 referrals in 2012-2013.)

GOAL - 4.1

Students will be provided an engaging and safe learning environment. BESD will establish a proactive system of socioemotional support. Attendance rates will improve on a year-to-year basis. The school climate survey administered to parents will demonstrate a year-to-year improvement.

METRICS & OUTCOMES - 4.2

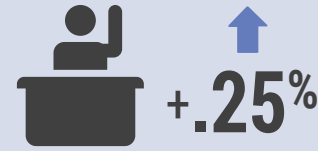

SUBGROUPS SERVED

-  All Students
-  English Learners
-  High Poverty
-  Foster Youth

SCHOOLS

-  
 -  
- All - 100%

STATE PRIORITIES SERVED

-  1. Basic Services
-  2. Academic Standards
-  3. Parent Involvement
-  4. Student Achievement
-  5. Student Engagement
-  6. School Climate
-  7. Course Access
-  8. Other Outcomes



GOAL #5

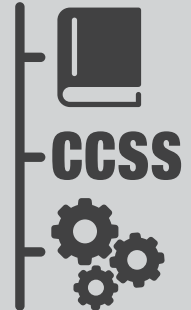

PROJECT-BASED & CCSS-ALIGNED CURRICULUM

NEED - 5.0

Based on findings from stakeholders and data, students will have equitable access to rigorous, well-rounded, standards-aligned curricula that assures readiness for a full-range of post-graduation options in order to become a contributing member of society. (Promotion Rate=75.38%.)

GOAL - 5.1

Common Core State Standards aligned curriculum will be incorporated into Transitional Kindergarten through the eighth grade. Project based learning opportunities will be incorporated into all grade levels.

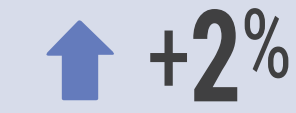

METRICS & OUTCOMES - 5.2



SUBGROUPS SERVED

-  All Students
-  English Learners
-  High Poverty
-  Foster Youth







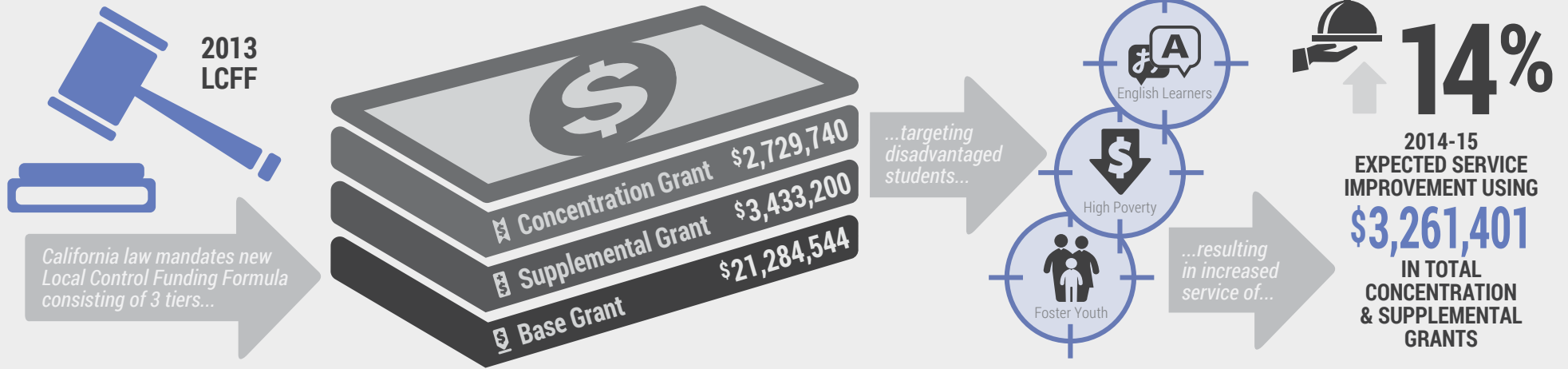



SCHOOLS











-  
 -  
- All - 100%

3. Actions, Services & Expenditures



Goal	Action / Service - Year 1	Amount	Target	Budget Source
<p>CONTENT AREA PROFICIENCY & ACHIEVEMENT</p>	1.1 - Hire Certificated Staff to reduce class size (K-3, all Elementary Schools)	\$320,000	<p>All Students</p>	LCFF
	1.2 - Assure student digital literacy (software - licenses & accessories)	\$25,000		LCFF, Title I
	1.3 - Strong Intervention Program (Materials, Professional Development, Stipends / Substitutes)	\$70,000		LCFF, Title I
	1.4 - Differentiated instruction / GATE program (Materials, Professional Development, Conferences / Substitutes)	\$40,000		LCFF, Title I, Lottery
	1.5 - Align current curriculum and resources with CCSS and ELD standards (English Language Arts Textbooks, Professional Development, Substitutes, Synced Solutions Software)	\$580,000		LCFF, CCSS, Lottery
	1.6 - Provide ongoing collaboration time for teachers (CCSS / English Language Development curriculum & student data analysis - Stipends/substitutes)	\$50,000		Title I, II
	1.7 - Early identification / intervention for struggling students (parent workshops, assessment tool, extended learning, Summer Academies - all Elementary Schools)	\$238,000		LCFF, Title 1, Migrant
	1.8 - Build a culture of data analysis (Student Informational Systems, Data Analysis Personnel to prepare reports)	\$75,000		LCFF
	1.9 - Targeted intervention support to ensure academic success (materials, 2 IT technicians, 1 IT manager, 2 K-3 Intervention Teachers, 4 District Resource Teachers, Extended Learning Academy, Senior Director of C&I)	\$1,299,000		LCFF

 Goal	 Action / Service - Year 1	 Amount	 Target	 Source
 <p>ALL LEP STUDENTS ENGLISH PROFICIENT</p>	<p>2.1 - Develop and implement rigorous, cohesive, and standards aligned instruction for English Learners to assure they attain proficiency in the English language (Professional Development Stipends, Substitutes, 2 District Academic Coaches, Consultant, 6 Paraeducators, Teacher Mentor, 6 teachers, Director of Special Projects, Traveling Conference, Rentals/Leases/Repairs)</p>	<p>\$1,342,000</p>	 <p>English Learners, Foster Youth, Low Income</p>	<p>LCFF</p>
 <p>HIGHLY QUALIFIED TEACHERS</p>	<p>3.1 - Hire properly credentialed teachers (recruit/hire based on qualifications, trainings - BTSA, substitutes, support providers, professional development)</p> <p>3.2 - Provide specialized course training for staff by Academic Coaches, Resource Teachers & additional consultants to meet unique & individual academic, emotional, and social needs of all students (targeted to Physical Education, Music, Art, STEAM, Technology, Dealing with disabilities, Behavioral, Classroom management, CCSS, History, Cultural Sensitivity, Student Information System, Writing)</p>	<p>\$80,000</p> <p>\$202,000</p>	 <p>All Students</p>	<p>LCFF, Title I, Title II</p> <p>LCFF, Title I, Title II, Title III, CCSS</p>
 <p>SAFE & ENGAGING LEARNING ENVIRONMENT</p>	<p>4.1 - Utilize community resources to educate parents on the importance of school attendance (consultants/speakers, stipends, materials, 2 Child Welfare Attendance Clerks, School Attendance Review Board Officer, School Resource Officer)</p> <p>4.2 - Expansion of Saturday School for Attendance Recovery (curriculum, stipends, materials, incentives)</p> <p>4.3 - Incentives & rewards for improved attendance</p> <p>4.4 - Two mental health specialists to support students social & emotional needs</p> <p>4.5 - District wide character education program (materials, resources, supplies, speakers, professional development)</p> <p>4.6 - District Parent Center (parent portal, websites, Telephone Communication System, childcare, translators, materials, technology)</p> <p>4.7 - Classes for Parents (Instructors Stipends, materials, childcare)</p>	<p>\$192,000</p> <p>\$25,000</p> <p>\$25,000</p> <p>\$205,000</p> <p>\$37,000</p> <p>\$54,000</p> <p>\$11,000</p>	 <p>All Students</p>	<p>LCFF, Title I, Lottery</p> <p>LCFF</p> <p>LCFF, Title I</p> <p>LCFF, Mental Health</p> <p>LCFF, Title I</p> <p>LCFF, Title I</p> <p>LCFF, Title I</p>

 Goal	 Action / Service - Year 1	 Amount	 Target	 Source
 <p>SAFE & ENGAGING LEARNING ENVIRONMENT <i>(continued...)</i></p>	4.8 - Family activities during and after school (stipends, security for special events, childcare)	\$21,000	 All Students	LCFF, Title I
	4.9 - Maintain facilities in a regular and timely manner (equipment, 1 additional skilled maintenance worker)	\$60,000		LCFF
	4.10 - Develop ongoing maintenance standards (Professional Development for custodial, gardening, staff, & bus drivers)	\$10,000	LCFF	
	4.11 - Increase availability of technology & technology support for staff (hardware, software, 2 IT technicians, 1 IT manager, Professional Development)	\$350,000	LCFF, Title I, Title II, CCSS	
	4.12 - Provide a safe learning environment that fosters high academic achievement (campus security, Licensed Vocational Nurse, Child Welfare Attendance, Mental Health Therapist, 3 Counselors)	\$620,401		LCFF
 <p>CCSS ALIGNED CURRICULUM</p>	5.1 - Enhance learning with real world hands on experiences (resources, field trips, virtual technology, speakers/consultants, specialized training for teachers)	\$82,000	 All Students	LCFF, Title I, Lottery
	5.3 - Continuous coordination & articulation between elementary, junior high & high schools (substitute costs, stipends, materials)	\$15,000		LCFF, Title I, Title II
	5.4 - Equitable access to rigorous well rounded standards aligned curriculum (supplemental materials, 6 qualified paraeducators)	\$100,000		LCFF, Title I, II, III, Lottery

This infographic provides a high-level summary only. For more specific details, please refer to the accompanying LCAP narrative plan.

©2015 solutions@goboinfographics.com